

MPPT SOLAR CHARGE CONTROLLER

SC 20 Pro

SC 30 Pro

SC 40 Pro

SC 60 Pro

Operating Instructions

ECTIVE

TABLE OF CONTENTS

Welcome	1
Scope of Delivery.....	2
Device Overview	3
General Information	4
Safety Instructions.....	8
Installing the Device	11
Operation	18
Status LEDs.....	22
LCD Display.....	20
Troubleshooting	28
Operation via the connectIVE App	29
Technical Data.....	31
Storage and Maintenance.....	33
The SC PRO in the ECTIVE EcoSystem	33
Service / Complaints	35
Disposal	35
Stay in Touch!	36

WELCOME

Hi, nice to meet you! Ready to get ECTIVE?

Thank you for choosing an ECTIVE SC PRO MPPT solar charge controller!

The models of the ECTIVE SC PRO series act as a link between the solar module and the battery, thereby allowing for an efficient storage of solar power. The intelligent charge controllers operate fully automatically, are maintenance-free and, thanks to the innovative MPPT technology, ensure gentle and efficient charging currents that are 10% to 30% higher than those of conventional controllers. This results in optimal power utilization of the solar system and the shortest possible charging times. This performance advantage is particularly noticeable in unfavorable weather conditions, such as winter, snowy weather and diffuse sunlight.

ECTIVE SC PRO charge controllers work perfectly with different battery technologies, such as conventional wet batteries, Gel and AGM batteries, as well as state-of-the-art LiFePO₄ batteries. A charging characteristic optimized specifically for each technology ensures efficient and gentle charging that preserves battery life. A practical DC output rounds off the ECTIVE SC PRO charge controller: Various 12V or 24V consumers (in the case of ECTIVE SC 60 PRO: 12V / 24V / 36V / 48V) can be operated directly with solar power by simply plugging them into the SC Pro's respective output.

Operating the ECTIVE SC PRO is also particularly intuitive and uncomplicated: The versatile display reliably shows all important values. As a convenient alternative, you can monitor the operation of your solar system from your smartphone or tablet via a Bluetooth connection.

 Please read this manual carefully before installing and operating the device and follow all safety, installation and operating instructions!

SCOPE OF DELIVERY

To make the installation and operation of your ECTIVE SC PRO solar charge controller as smooth, efficient and safe as possible, various accessories are included with your device. Please check that the scope of delivery is complete before installing and using the device:

1. ECTIVE SC Pro

High-quality, intelligent solar charge controller
(ECTIVE SC 20 Pro, SC 30 Pro, SC 40 PRO or SC 60 Pro)

2. Mounting template (only SC 20 PRO)

With the suitable mounting template you can easily mark the drill holes where you want to install your ECTIVE SC PRO solar charge controller.

3. External temperature sensor

The supplied temperature sensor measures the temperature of the battery connected to the charge controller. This allows the charging process to be optimized: the battery is charged faster and more gently which prolongs battery life.

4. Operating Instructions

This detailed operating manual for the ECTIVE SC Pro

DEVICE OVERVIEW

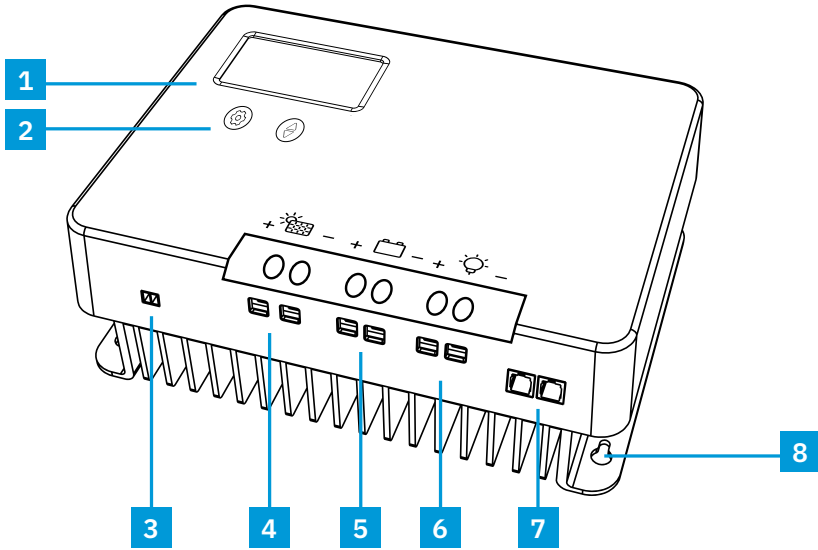

1. Interactive LCD display
2. Input keys
3. Connection for external temperature sensor
4. Solar connections
5. Battery connections
6. Connections for DC loads
7. RS485(RJ12)/CI-/CAN-Bus connectors for connecting two ECTIVE SC PRO charge controllers (parallel charging) or to connect an external monitor.
8. Mounting holes

GENERAL INFORMATION

What is a solar charge controller?

Solar charge controllers operate as a link between solar panels and batteries to enable efficient and gentle charging of the battery.

The advanced charge controllers of the ECTIVE SC PRO series offer numerous functions that make the operation of the solar system safe, efficient and extremely convenient. The charge is constantly adjusted and optimized based on a wide variety of factors such as battery technology, solar power and temperature. The innovative „Maximum Power Point Tracking“ (MPPT) technology continuously maximizes the input voltage so that the solar system can always provide the maximum power. This allows efficiency increases of up to 30% compared to conventional PWM charge controllers.

Thanks to their robust and straightforward design, ECTIVE SC PRO charge controllers are easy to install and connect to the other elements of your solar system. The operation of the charge controller is also simple and intuitive: All values can be easily read on the integrated display and thanks to the integrated Bluetooth module, you can monitor and control the operation of your solar system from your smartphone or tablet.

▶ Ready to get ECTIVE!

[Quick-Start Guide](#)

1. familiarize yourself with the safety instructions on p. 8
2. Install the ECTIVE SC PRO according to the instructions on p. 11.
3. Connect the supply battery and the solar module. Be sure to observe the notes in the section „Installing the Device“ .
4. Optional: Download the app for your iOS or Android device and connect it to the Bluetooth module of the solar charge controller.

Overview of features and functions

- The power output of the solar modules is continuously monitored fully automatically. Multiple MPPT charging algorithms are used to enable optimal charging in a wide range of weather and temperature conditions.
- Individually optimized charging modes ensure efficient and gentle charging of different battery technologies, such as wet, AGM, Gel and lithium batteries. Additionally, parameters can be set manually („USER“ mode).
- Automatic detection of battery voltage for wet, AGM and Gel batteries (12 or 24V; for SC 60 Pro: 12, 24, 36 or 48V).
- The integrated Bluetooth module enables convenient monitoring and operation via app from a smartphone or tablet.
- Charge values are recorded for up to 300 days, also accessible via the Bluetooth app.
- RS485 connection for external monitors (RJ12) or for connecting two identical ECTIVE SC PRO charge controllers to charge the battery system in parallel. CI and CAN bus connection for integration into existing monitoring systems.

Comprehensive electronic protection mechanisms:

- Battery overcharge protection
- Battery deep discharge protection (when using DC load)
- PV overvoltage protection
- Overheating protection
- Charge controller protection when nominal power is exceeded (up to 25%)
- DC consumer short circuit protection
- DC consumer overcharge protection
- Reverse polarity protection for battery and PV

Advantages of MPPT technology

Solar charge controllers with advanced MPPT technology automatically determine the maximum power output (MPP) of the connected solar modules several times per second. Using high-frequency, high-efficiency switching controller technology, the controller transforms the solar module's voltage surplus to a higher charge current for the battery. This charging current gain ensures shorter charging times and the best possible power utilization of the solar system.

Thanks to this modern microprocessor-based controller technology, the efficiency of the charge is 10% to 30% higher than conventional controllers. The performance plus is particularly evident at cooler times of the year and, for example, during snowy periods or low and diffuse sunlight conditions

Different charging characteristics also allow optimal charging of batteries of different technologies, including flooded, sealed/AGM, Gel as well as lithium.

Intelligent protection mechanisms

Various intelligent systems protect the charge controller, battery, solar panels as well as connected loads from various risks and optimize operation.

The spike-free, regulated charging voltage prevents overcharging of the batteries and thus allows monitoring-free charging. Other safety mechanisms protect against overload, overheating, reverse polarity and battery back discharge (when solar power is too low, e.g. dusk, night, etc.), among other dangers.

Thanks to parallel/buffer operation, charging specifications are respected even during simultaneous operation of a DC load.

Overcharge protection: if the solar power is too high or the battery is full, the charging current is throttled.

„IU1oU2“ charging characteristic: The defined charge voltage increase (U1) prevents harmful acid stratification in lead batteries and ensures equalization charging of the individual battery cells (lead and LiFePO₄). This is followed by the automatic trickle charge (U2).

Charging cable compensation: Voltage losses on the charging cables are automatically compensated.

Integrated on-board power supply filter: Ensures problem-free parallel operation with wind and motor generators, mains chargers, alternators, etc.

Connection for battery temperature sensor: By accurately measuring the temperature of the battery, charging can be dynamically adjusted to make it as efficient and gentle as possible.

For lead-acid batteries, the automatic adjustment of the charging voltage to the battery temperature: this results in a better full charge of the battery in cold conditions, and avoids unnecessary battery gassing and stress in high temperatures.

The temperature sensor also protects LiFePO₄ batteries that do not have a temperature cut-out (ECTIVE LiFePO₄ batteries always have one) at high and especially low temperatures. If the temperature is likely to fall below 0 °C during operation, a sensor is strongly recommended.

SAFETY INSTRUCTIONS

 To avoid injury and prevent damage to electrical equipment, please observe the following safety instructions before operating the ECTIVE SC PRO solar charge controller.

- Only connect solar modules to the solar input terminals. Never connect other power sources to these inputs.
- Never connect an AC source to this DC-DC device. This could damage the charge controller and cause a fire!
- When using lithium batteries, be sure to check the connections and avoid reversing the polarity.
- Do not connect an inverter to the DC consumer port of the charge controller. This could cause a short circuit or even a fire due to an overcurrent.
- Keep the charge controller and batteries out of the reach of children.
- Avoid having a solar panel connected to the charge controller for long periods of time without also having a battery connected. This could damage the display of the charge controller.
- Solar modules can generate high voltages and currents! Make sure that the solar panels are completely covered during installation and connection of the charge controller. We recommend having a qualified electrician perform the installation.
- Use the correct fuses in your solar installation to avoid damage to the charge controller or batteries. Feel free to contact our customer service if you have any questions or are unsure.
- When connecting the solar module and the battery, sparks may be

generated. Make sure you wear appropriate protective equipment.

- When grounding the PV system, choose a negative ground.
- Make sure to use the correct cable cross-sections for the connections. Observe the notes in the „Installation“ section.
- Always observe the specified nominal voltages when charging batteries and connecting loads.
- Make sure that the maximum power rating of the solar modules (Wp) and the maximum permissible voltage (Voc) are compatible with your charge controller.
- Use the specified cable cross-sections at the charge outputs and at the panel input.
- Only use the charge controller in a well-ventilated room. Ensure that it is protected from rain, moisture, dust, aggressive battery gases and condensation
- Regularly vent the battery room to protect the charge controller from aggressive battery gases.
- Never use the device in locations where there is a risk of gas or dust explosion!
- Only operate the solar charge controller when it is in technically flawless condition.
- Lay the cables in such a way that damage is ruled out and ensure that they are well fastened.
- Always lead the connection cables of the solar panels to the MPPT solar charge controller from below so that penetrating moisture cannot get into the controller and damage it.

- Never lay 12 V or 24 V cables together with 230 V mains cables in the same cable duct/conduit.
- Regularly inspect live cables or lines for insulation faults, breaks or loose connections and rectify any defects immediately.
- It is essential to disconnect the device from all connections during electrical welding work or work on the electrical system.
- If any of the instructions, settings, regulations and characteristic values described in this manual are not clear, please consult a professional.
- Compliance with building and safety regulations of all kinds is the responsibility of the user.
- Observe the safety regulations of the battery manufacturer.
- When installing the solar panels, be sure to follow the manufacturer's instructions. Failure to do so may result in personal injury and material damage.

INSTALLING THE DEVICE

Mounting the solar charge controller

1. Select a secure, dry location for mounting the solar charge controller where it is protected from direct sunlight, precipitation, condensation, and waste heat from other equipment or an engine. To prevent the charge controller from overheating, ensure adequate air circulation. Ensure that there is a minimum distance of 20 cm from the floor or other equipment below the charge controller and a minimum distance of 10 cm above the charge controller.
2. When choosing the installation location, keep in mind that the connected batteries are also within their respective temperature ranges: they should be protected from external heat sources as well as from temperatures that are too low. For LiFePO₄ batteries, the temperature should be above 0°C, unless the battery was specifically designed for use in low temperatures.
3. Mount the solar charge controller so that the connections point downwards. This protects the charge controller from incoming water.
4. Drill four holes and attach the solar charge controller. Make sure it is securely fastened. For the ECTIVE SC 20 PRO, use the supplied mounting template to mark the position of the drill holes.
5. Proceed to connect the battery and solar modules and connect a DC load and other accessories if necessary. When doing so, follow the instructions given below:

The connections

Observe the required cable cross-sections given below for all electrical connections!

1. First connect the positive pole of the battery to the positive battery connection of the solar charge controller.
2. Then connect the negative terminal of the battery to the negative battery

terminal of the solar charge controller.

3. Make sure that the solar modules are completely covered during installation. If sunlight falls on the surface of the panels during connection, there is a risk of electric shock! In addition, the system could be damaged in the event of reverse polarity.
 4. Connect the positive output of the solar module to the positive solar input of the charge controller.
 5. Connect the negative output of the solar module to the negative solar input of the charge controller.
- **Optional:** Connect a DC load to the charge controller (20A).
 - **Optional:** Connect the temperature sensor to the charge controller.
 - **Optional:** Download the ECTIVE app on your iOS or Android device to monitor and control the solar system from your smartphone or tablet.

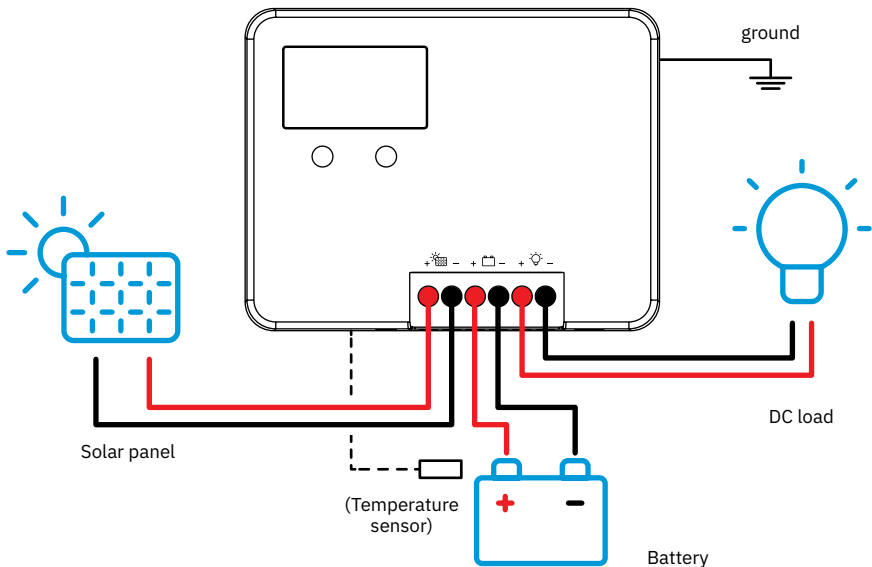

Required cable cross sections

Be sure to use the cable cross sections listed here for all connections and electrical connections:

Solar input current	5A	10A	20A	30A	40A	60A
cross section	1.5mm ²	2.5mm ²	5mm ²	8mm ²	10mm ²	12mm ²
AWG	15	13	10	8	7	6

Charging multiple batteries

It is possible to charge two or more batteries of the same voltage (12 V). To do this, connect the batteries in parallel: The positive terminals of the batteries are coupled and connected to the positive battery terminal of the solar charge controller. Likewise, the negative terminals of the batteries are coupled and connected to the negative battery terminal of the charge controller.

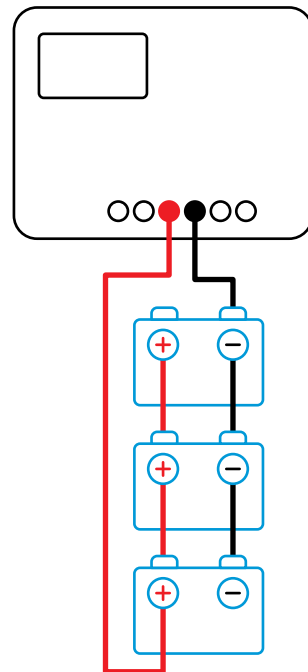

Connecting multiple solar panels

To achieve a higher yield from your solar system, you can use multiple solar panels. This will result in a higher average solar output especially when the solar system partially shaded due to the position of the sun or factors such as leaves, branches and debris.

For this purpose, several solar panels can be connected in parallel or in series. Please refer to the following connection diagrams:

Parallel connection

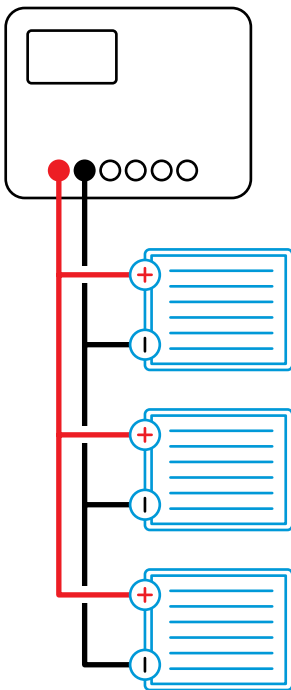

Series connection

Observe max. input voltage!

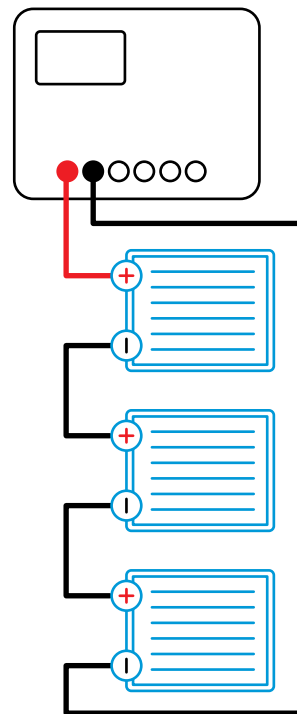

Reverse polarity when connecting the battery

In the event of reverse polarity, the internal fuse of the solar charge controller is triggered.

Possible source of error for falsified current measurement

The ECTIVE SC PRO solar charge controller automatically performs continuous current measurements in order to intelligently optimize the charging process. To ensure that these measurements are not falsified, it is important that there is no other electrical connection between the negative output of the solar modules and the negative terminal of the battery or the car body. Such a connection could be caused, for example, by connecting another solar charge controller or damaging the insulation on the roof cable gland. Therefore, do not connect another solar charge controller to this solar system and regularly check all electrical wiring and insulation.

Using two charge controllers to charge the battery system in parallel

To reduce charging time, you can use two identical ECTIVE SC PRO charge controllers to charge your battery system in parallel. To ensure safe and efficient charging, the charge controllers must be able to communicate with each other. Connect the two charge controllers with the corresponding cable (ECTIVE TN5603), which is available separately. This allows the operation of the devices to be coordinated and synchronized with each other so that they always operate in the same charging mode. This helps prevent damage to the battery, especially after long periods of operation, and prolongs battery life. In addition, synchronizing the charge controllers allows optimal use of the available solar energy, resulting in shorter charging times.

Connecting a DC load (Optional)

12V / 24V; for ECTIVE SC 60 PRO: 12 / 24 / 36 / 48V

Small 12 and 24V consumers (max. 20A) can be operated at the DC output of the solar charge controller, for example 12/24V fans, car relays or even refrigerators with D+ control input. Observe the manufacturer's specifications and operating instructions for the consumer and ensure that the connection is not short-circuited or overloaded under any circumstances.

Temperature sensor (optional)

A temperature sensor may be used to measure the battery temperature of the connected supply battery. This enables even better control of the charging process so that the battery is charged even more gently and efficiently. Connect the sensor to the corresponding connection socket. Make sure that the measurements of the sensor are not influenced by heat sources such as engine block, exhaust, heater or similar! Observe the following instructions depending on the battery technology:

Lead-acid, Gel, AGM batteries:

In order to be able to measure the battery temperature optimally, the temperature sensor should be screwed onto the negative or positive pole of the battery. Alternatively, it can also be mounted on the long side in the center of the battery housing. This enables improved temperature compensation:

At low temperatures, the charging voltage is increased and the battery is charged faster.

At particularly low temperatures, the charging voltage is limited to protect all connected devices.

At high temperatures, the charging voltage is reduced. In this way, battery gassing can be reduced and the service life of the battery increased.

At particularly high battery temperatures (from +50 °C), the charging voltage is reduced to the safety charging voltage of approx. 12.80 V to protect the battery and the maximum charging current is halved.

Battery charging then no longer takes place, but any connected loads continue to be supplied by the MPPT solar charge controller and the battery can cool down. Afterwards, charging continues automatically.

LiFePO₄ batteries:

In order to be able to measure the battery temperature optimally, the temperature sensor should be screwed onto the positive pole of the battery, as this is the cooler side in most cases for LiFePO₄ batteries. The temperature at the negative terminal is often distorted by the waste heat from internal battery fuses or internal electronics.

At battery temperatures outside the regular temperature range (below -20°C or above 50°C), the charging voltage is reduced to the safety charging voltage of approx. 12.80V to protect the battery and the maximum charging current is halved.

Battery charging then no longer takes place, but any connected loads continue to be supplied by the MPPT solar charge controller until the temperature of the battery is back in the regular range. The battery is then automatically charged again.

At temperatures below 0°C, the charging current is greatly reduced to protect the battery and longer charging times are to be expected.

In the event of a missing sensor, a cable break or short-circuit of the sensor lines, the solar charge controller detects the faulty readings and then automatically switches back to the standard charge voltages recommended by the battery manufacturers.

Any questions?

If you encounter problems that you cannot solve yourself, please contact our customer service. There you will receive qualified help.

active.de/kontakt

OPERATION

Solar charge controllers of the ECTIVE SC PRO series operate fully automatically. You can monitor the values of the operation on the integrated display or via Bluetooth functionality from your iOS or Android device.

Observe the following instructions for optimal operation of your solar system:

Battery parameters

ECTIVE SC PRO charge controllers charge batteries of different technologies with a specific charging program. You can select the program via the LCD display (see section „LCD display“). The different programs operate with the parameters given below. The variable „n“ is used as a multiplication factor, depending on the battery voltage:

- Battery voltage 12V: n = 1
- Battery voltage 24V: n = 2
- Battery voltage 36V: n = 3
- Battery voltage 48V: n = 4

Battery type	FLD	SEL	GEL	LI
Equalize charge voltage	14.8 V * n	14.6 V * n	-	-
Boost charge voltage	14.6 V * n	14.4 V * n	14.2 V * n	14.2 V * n
Float charge voltage	13.8 V * n	13.8 V * n	13.8 V * n	-
boost charge recovery voltage	13.2 V * n	13.2 V * n	13.2 V * n	-
Over-discharge recovery voltage	12.6 V * n	12.6 V * n	12.6 V * n	-
Over-discharge voltage	11.1 V * n	11.1 V * n	11.1 V * n	11.1 V * n
Automatic temperature compensation	-3mV/2V/°C	-3mV/2V/°C	-3mV/2V/°C	-

Lithium batteries

When the battery technology „LI“ is selected, the values „Boost charge: voltage“ and „Deep discharge limit“ can be adjusted manually.

„USE“: Advanced User Mode

If the advanced battery mode „USE“ has been selected, the numerous values can be adjusted manually. The preset default values correspond to those of the „GEL“ mode.

Deep discharge

Avoid the deep discharge of your battery!

In lead batteries, sulfation of the lead grids occurs during deep discharge, especially at high ambient temperatures. This reduces the capacity of the battery permanently. If the sulfation has not yet progressed too far, the battery can recover some of the lost capacity after a few charge/discharge cycles.

In the case of LiFePO_4 batteries, deep discharge must be avoided at all costs, as this can lead to permanent damage to the battery!

Partial discharge

In batteries with LiFePO_4 technology, no harmful „memory effect“ occurs during charging after partial discharge, which permanently reduces the capacity. This means that partially discharged LiFePO_4 batteries can be charged without hesitation. To avoid a deep discharge, you should fully recharge partially discharged LiFePO_4 batteries as soon as possible.

Ensure that the batteries are kept cool and dry. For LiFePO_4 batteries, the ambient temperature should be above 0°C if possible.

If insufficient solar power is available to charge the batteries due to lack of sunlight, they should occasionally be fully charged with a mains charger.

LCD DISPLAY

The interactive LCD display of your ECTIVE SC PRO solar charge controller shows all relevant values, functions and, if applicable, error messages. The four keys below the display can be used to select different display modes and make settings on the device.

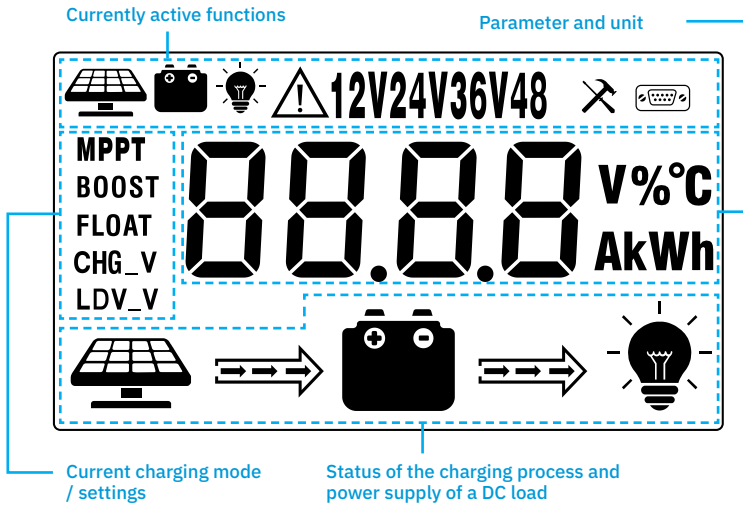

Symbols on the LCD display

Symbol	Meaning
	On: Battery is being charged with solar power Off: No charging with solar power
	On: DC load is being supplied with power Off: No load on DC output
MPPT	Charging mode: MPPT

BOOST Charging mode: Boost charge

FLOAT Charging mode: Trickle charge

CHG_V (Only for lithium batteries and manual settings)
On: Charging voltage is currently being set
Off: Charging voltage has been set

LDV_V (Only for lithium batteries and manual settings)
On: Discharge voltage is currently being set
Off: Discharge voltage has been set

12V24V36V48V Current system voltage



On: There is a system error
Off: There is no system error



On: Settings mode: Settings can be adjusted
Off: Display mode



On: Communication via Modbus
Off: No communication via Modbus



On: Solar radiation detected
Off: No solar radiation detected
Slow flashing: Overvoltage



On: A battery is connected and functioning correctly
Off: No connected battery can be detected
Slow flashing: Battery reverse polarity or deep discharged



On: DC load is on
Off: DC load is off
Fast flashing: Short circuit on consumer
Slow flashing: Overload at DC output

Buttons on the LCD display

With the four buttons below the LCD screen, you can display different values of your solar system and adjust settings.

There are two modes the LCD screen can be in:

- The Display Mode
- The Settings Mode

Display Mode

In the display mode, different values of the solar charge controller are displayed. You can recognize that you are in the display mode when the symbol ✕ is not visible on the screen.

By pressing the  button, you can cycle through different pages of the display. On each page the corresponding values are displayed:



Battery voltage (default page)

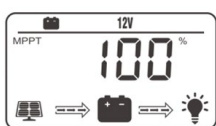

Battery capacity

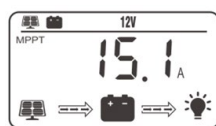

Charging current

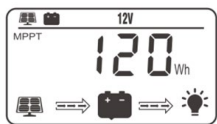

Charge: Watt hours

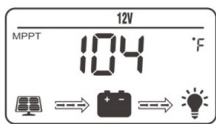

Charge controller temperature



Error code

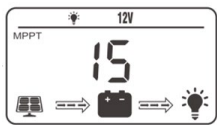

DC Load: Mode

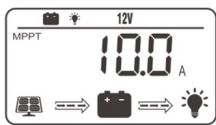

DC Load: Current

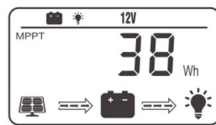

DC Load: Watt Hours

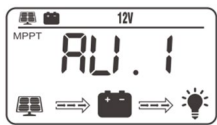

Battery Type

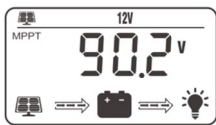

Charging PV Voltage

If „Manual mode“ is selected on the „DC load: Mode“ page, you can switch off the DC load manually in the display mode by pressing the key .

30 seconds after the last input, the display mode switches back to the output display and shows the battery voltage.

20 seconds after the last input, the display illumination turns off automatically.

If the charge controller detects an error, the „Error code“ page is automatically displayed. Use the table on p. 28 to identify and correct the error.

From the display mode, you can switch to the **setting mode** by pressing and holding the key  (note: this does not work on the „DC load: mode“ page).

The Settings Mode

In the settings mode, you can change individual settings of the solar charge controller. You can tell that you are in display mode by the icon  in the upper right corner of the display

Set battery type:

In the settings mode, you can set the battery type. Use the  button to switch between the following battery technologies

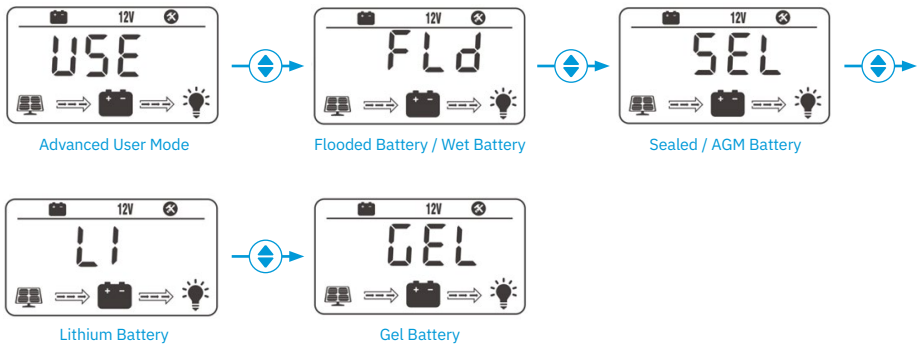

Press and hold the button  to confirm the selected battery technology

When the charge controller is set to „FLD“, „SEL“ or „GEL“ mode, the optimum parameters for the respective battery technology are automatically set.

In „LI“ mode, some parameters can be adjusted manually to optimize operation for the connected lithium battery.

In „USE“ mode, almost all parameters can be adjusted manually.

Adjust parameters (LI and USE battery types):

When selecting battery technology, if the display is set to „LI“ or „USE“ mode, press the button  briefly to enter the advanced battery settings.

Selecting parameters:

A short press of the button  will cycle through the parameters to be changed (see below).

Change parameters:

Use the  button to change the value of the selected parameter.

Save changes:

Press and hold the button  for a moment to save the changes made and return to display mode

Discard changes:

Press and hold the  button to return to the display mode without saving the changes .

Changing Parameters (Lithium Batteries):

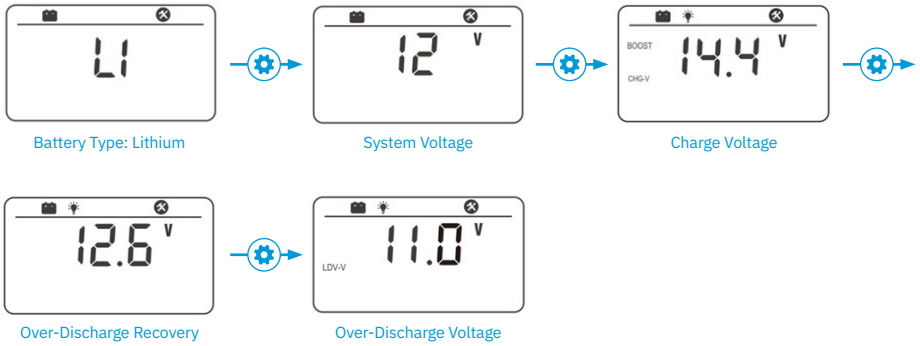

Changing Parameters (USER Mode):

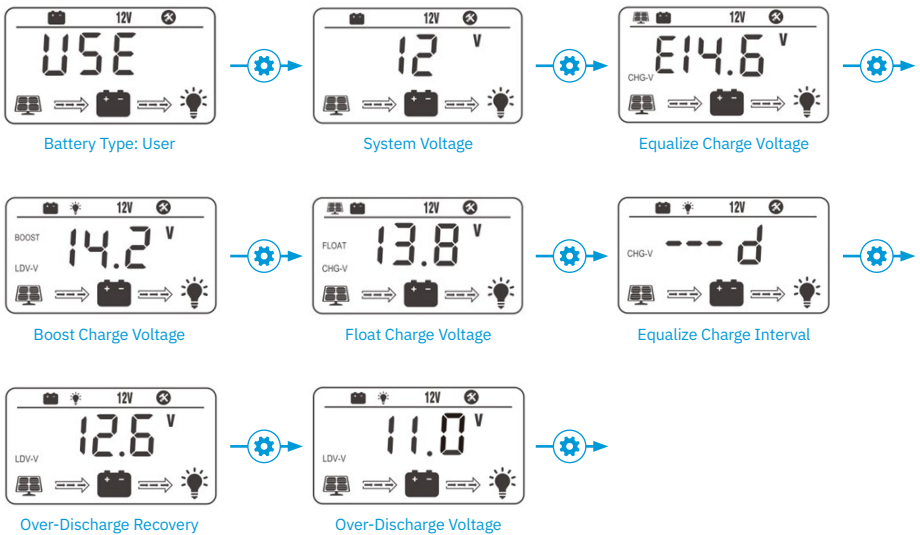

DC load settings:

On the „DC Load: Mode“ page of the display mode, you can switch to the DC Load settings by pressing and holding the button .

Select mode:

Use the and  button to switch between the different modes.

Confirm mode:

Press and hold the button  to confirm the selected mode.

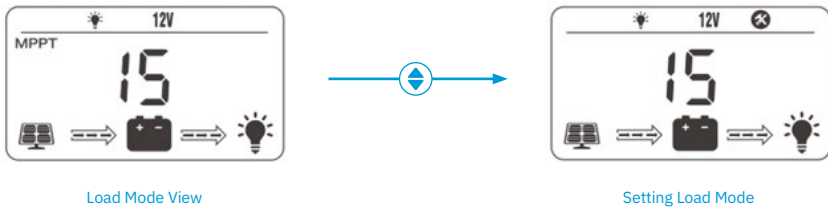

Discard changes:

Press and hold the button  to return to the display mode, discarding changes.



Mode	Description
0	Automatic control according to daylight: DC power is turned on when no daylight can be detected.
1-14	Automatic control according to daylight with timer: The DC load is switched on when no daylight can be measured. It is automatically switched off again after [1-14] hours. Enter the number of hours for the timer here.
15	Manual mode: The DC consumer is switched on or off when the button  is pressed in the display mode
16	Test mode: The DC consumer is switched on and off in rapid succession.
17	Always On: The DC load remains on continuously.

Temperature Unit Setting:

In the temperature display interface, enter the temperature unit setting mode by long pressing the button . You can switch between °F (Fahrenheit) and °C (Celsius) by pressing the button .

Long press  to confirm the selected unit and exit.

Long press  to exit the setting without saving.

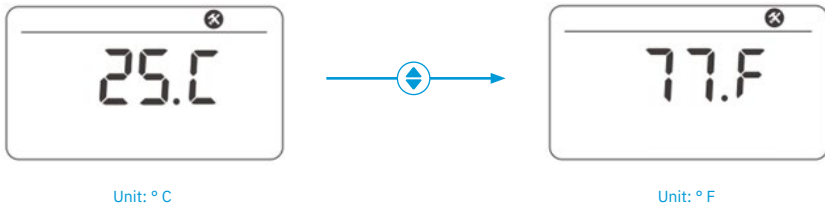

TROUBLESHOOTING

ECTIVE SC PRO charge controllers automatically detect a variety of possible errors. In this case, the error LED lights up (see p. 22) and an error code appears on the LCD display. In the following overview you will find the meaning of each error code so that you can correct the fault

Error code	Error description and troubleshooting
E00	There is no error.
E01	Deep discharge of the battery: Battery voltage is too low. DC consumer is not supplied with power until the battery is sufficiently charged again.
E02	Battery overvoltage: Battery voltage is above the limit of the charge controller. Please check if the battery is compatible with the charge controller.
E04	Short circuit on the DC load: Remedy the short circuit.
E05	Overload of the DC load: Reduce the load or use a charge controller with a higher output current.
E06	Overheating of the charge controller: The temperature is above the operating range of the charge controller. Ensure that the charge controller can cool down.
E07	Battery overheating: The temperature measured by the external temperature sensor is too high. Ensure that the battery can cool down.
E10	Solar overvoltage: The voltage of the solar modules is higher than the nominal voltage of the charge controller. Reduce the voltage of the connected solar modules.
E13	Reverse polarity of the solar module: The solar modules are connected incorrectly. Reconnect them and make sure that the polarity is correct. (Error message is not displayed on ECTIVE SC 60 Pro! The device is nevertheless protected)
E14	Reverse polarity of the battery: The battery is connected incorrectly. Reconnect it and make sure that the polarity is correct.

OPERATION VIA THE CONNECTIVE APP

Thanks to the integrated Bluetooth module of the ECTIVE SC PRO, you can conveniently monitor and control the operation of your solar system via the **connECTIVE app** on your iOS or Android device.

If the Bluetooth signal is not strong enough due to the installation location of your charge controller, you can connect an **external Bluetooth** module. Please refer to the instructions in the “Installation” section.

To connect your charge controller to your smartphone or tablet, please proceed as follows:

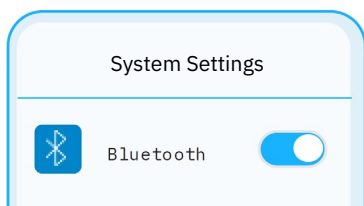

Aktivieren Sie die Bluetooth-Funktion auf Ihrem Endgerät.

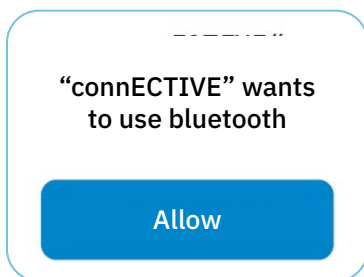

Erlauben Sie der connECTIVE App die Verwendung der Bluetooth-Funktion.

Download the **connECTIVE** app to your smartphone or tablet.

Ensure that the Bluetooth function is activated in the system settings of your device.

Open the **connECTIVE app** and, when prompted, allow the app to use the Bluetooth function.

Tap the plus sign on the app’s home screen to bring up the list of „**devices nearby**“. The charging controller should be listed here. When connecting for the first time, the device may appear as „BT1“ or the name may consist of a combination of letters and numbers. This name can be changed after a successful connection. If you cannot find a suitable device or the list is empty, please check the distance and that

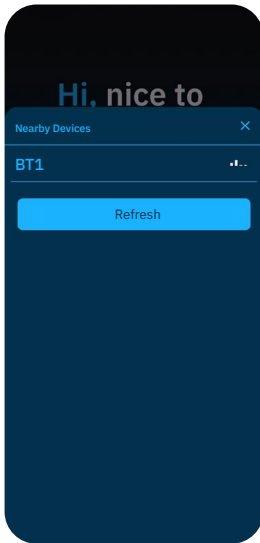

Select the charge controller or Bluetooth dongle from the list of available devices. You can then monitor the status of your charge controller from the app.

the charge controller is active. Tap on the device to establish the connection.

The **quick info tile** for your charge controller will now appear on the app's home page. The most important information, such as status, voltage and power, is displayed there. Tap on the tile to access the **product dashboard**, where you will find more detailed information about its operation.

Once the app and charge controller are **paired**, they will connect automatically as soon as the devices are within range and active.

We **update** the **connectIVE app** regularly. Please ensure that the relevant updates to the app are carried out on your device to ensure smooth operation.

Further information about the connectIVE app and detailed instructions can be found at www.ective.de/app.



TECHNICAL DATA

	SC 20 Pro	SC 30 Pro
Max. solar module power (Wp)	300/600 (12/24 V)	450/900 (12/24 V)
Charging mode	MPPT	MPPT
Max. solar module current	20 A	30 A
Max. solar module voltage	100 V	100 V
Min. solar module voltage	15 V	15 V
Battery nominal voltage (DC)	12/24 V	12/24 V
Charging current Batt. I	20 A	30 A
Self-consumption	12/10 mA	12/10 mA
DC consumer connection	20 A	20 A
Communication port	RS485 (MODBUS), CAN, CI-BUS	
Temperature range	-35 °C to +45 °C	
Dimensions (W x H x D)	180 x 140 x 71 mm	275 x 180 x 82,5 mm
Weight	1520 g	2600 g
Operating height	≤ 3000 m	
IP protection class	IP32	
ECE conformity	E57 10R06/02*0862*00	

	SC 40 PRO	SC 60 PRO
Max. solar module power (Wp)	600/1200 (12/24 V)	900/1800/2600/3200 (12/24/36/48 V)
Charging mode	MPPT	MPPT
Max. solar module current	40 A	60 A
Max. solar module voltage	100 V	150 V
Min. solar module voltage	15 V	15 V
Battery nominal voltage (DC)	12/24 V	12/24/36/48 V
Charging current Batt. I	40 A	60 A
Self-consumption	12/10 mA	12/10/8/6 mA
DC consumer connection	20 A	20 A
Communication port	RS485 (MODBUS), CAN, CI-BUS	
Temperature range	-35 °C to +45 °C	
Dimensions (W x H x D)	275 x 180 x 82,5 mm	310 x 210 x 90 mm
Weight	2600 g	4200 g
Operating height	≤ 3000 m	
IP protection class	IP32	
ECE conformity	E57 10R06/02*0862*00	

STORAGE AND MAINTENANCE

Solar charge controllers of the ECTIVE SC PRO series operate fully automatically and do not require any special maintenance. Basically, you should regularly check the connections, joints and insulation of your solar system and make sure that it meets the requirements according to the section „Safety instructions“

Battery life and performance:

- Choose an installation location that keeps the batteries cool. For LiFePO_4 batteries, the temperature should be above 0°C .
- Store batteries in charged condition and recharge them regularly. Recharge deeply discharged batteries immediately.
- Check the acid level of open lead-acid batteries regularly.
- When using LiFePO_4 batteries, make sure that they are complete batteries with BMS and safety circuitry. Avoid deep discharging at all costs!

THE SC PRO IN THE ECTIVE ECOSYSTEM

The solar charge controllers of the SC PRO series fit perfectly into the ECTIVE ecosystem, because they are compatible with all ECTIVE solar panel series as well as ECTIVE batteries of all technologies. This means that nothing stands in the way of a solar system consisting exclusively of high-quality and perfectly matched ECTIVE products.

For even shorter charging times, you can connect two ECTIVE SC PRO charge controllers with a corresponding connection cable (TN5603) and thus charge the battery system in parallel.

Compatible ECTIVE solar module series:



MSP Black

Reduced reflection for increased power.



MSP S Black

Higher efficiency due to Advanced-Cell-Technology.

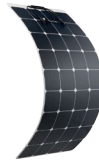

MSP Flex

Flexible panels for curved surfaces.



SSP Black

Innovative and efficient Shingle Technology.



SSP Flex Black

Flexible panels with Shingle Technology .



SSP Black Lightweight

Especially light Shingle panels with ETFE coating.



Portable solar modules

Portable panels für ultimate independence and mobility.

ECTIVE SunBoard | SunDock | SunWallet

Compatible ECTIVE battery technologies

ECTIVE Gel Batteries

The solution for small consumers

- DC Gel
- DC Gel Slim
- DC S Gel
- DC SC Gel

ECTIVE AGM Batteries

Batteries for power intensive consumers

- SC AGM
- DC AGM
- DC AGM Slim
- DC S AGM

ECTIVE LiFePO₄ - Batteries

Advanced premium batteries

- LC
- LC BT
- LC LT
- LC Under Seat
- LC Slim
- LC S LT

SERVICE / COMPLAINTS

If you have any questions about your device after purchase or during operation, we are happy to help you. To speed up the process, please provide information by email in advance, whenever possible with an explanation of the issue and photos. To contact us and for product returns, please use the following service address:

batterium GmbH, Robert-Bosch-Straße 1,
71691 Freiberg am Neckar, Germany
T: +49 7141 / 560 90 40 info@ective.de ective.de

Tip: When contacting us directly, please have your customer or invoice number and the article number ready.

In case you would like to return a product to us, please follow these guideline to ensure a quick and secure handling of the issue

- If possible use the original packaging as shipping carton.
- If you no longer have the original packaging, please use suitable (UN-certified) packaging to ensure adequate protection during transport.
- If the goods are not shipped in the original packaging or a UN-certified packaging, the goods are considered damaged and will therefore need to be billed when the item is returned.

Please enclose the following with the return shipment: Copy of the invoice, (Service Form), Reason for return, An exact and detailed error description

DISPOSAL

- Please recycle or dispose of the packaging material for this product.
- The German Electronic Equipment Act (ElektroG) regulates how to place electronic devices on the market, how to recycle and dispose of them.

Please note

In case of decommissioning of the device, please contact the nearest recycling centre or point of sale in order to get information about the disposal regulations.

STAY IN TOUCH!

You would like to learn more about ECTIVE and our products? Visit us our [website!](#)

You want to stay up to date or are looking for inspiration for your next camper conversion? Follow us on [Instagram!](#)

Still have a specific question? Our [customer service team](#) will be happy to take care of you. There you will receive fast, qualified help with concerns about our products!

Our goal is to make your life easier with our ECTIVE products. No matter if you are on the road with your camper, your boat or just your backpack. No matter if it's a trip, a festival or a professional photo shoot: You should be able to fully concentrate on your adventure or project. A reliable power supply that runs efficiently and safely in the background strengthens your back and you can take care of the essentials: Experiencing unforgettable moments and creating priceless memories.



batterium GmbH

Robert-Bosch-Straße 1 | 71691 Freiberg am Neckar | Germany
T: +49 7141 1410870 | info@ective.de | ective.de

© batterium GmbH, Edition 3,02/2026

(E57) 10R06/02*0862*00



ECTIVE

eine Marke der / a brand of

batterium GmbH

Robert-Bosch-Straße 1

71691 Freiberg am Neckar

Germany

Tel.: +49 7141 1410870

[ECTIVE.DE](https://www.ective.de)